

EN Installation instructions
FR Instructions d'installation
DE Hinweise zur Installation und zum Aufstellungsort
IT Istruzioni di installazione
RO Instrucțiuni de instalare
TR Montaj Talimatları

K54285EB_K54275NEB / HEB - Sliding

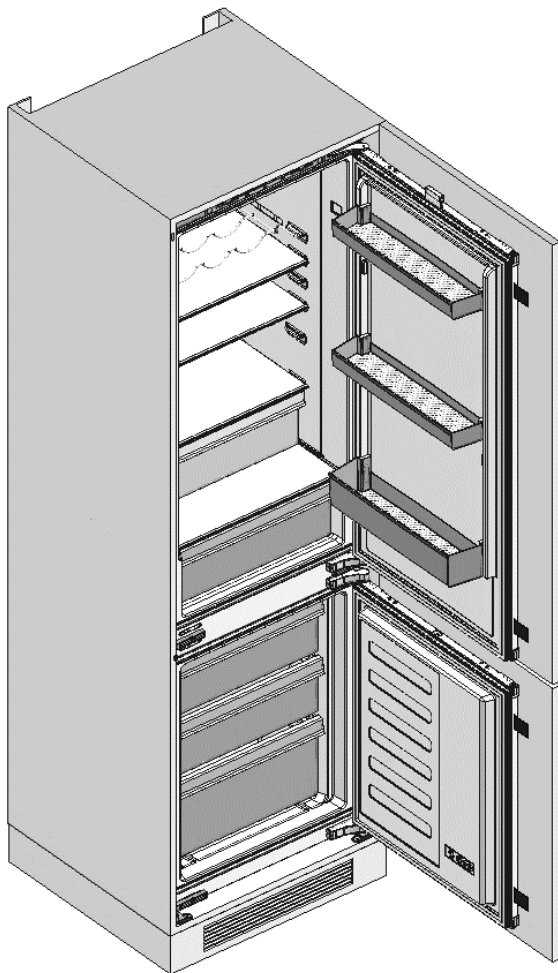

4578347715/AE

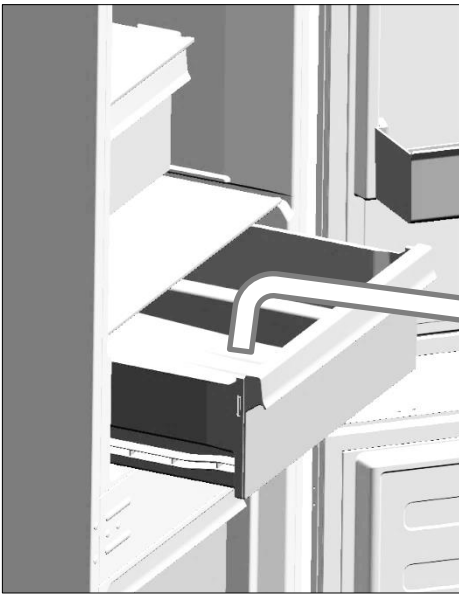

Spare included
Pièces incluses
Ersatzteile inklusive
Ricambi inclusi
Pieșe incluse
Dahil olan parçalar

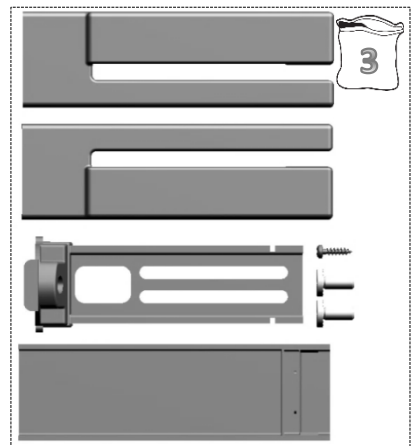
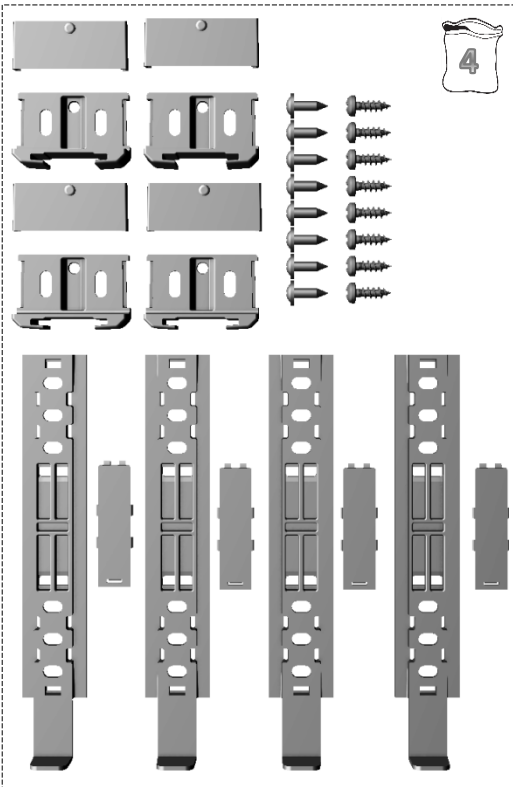
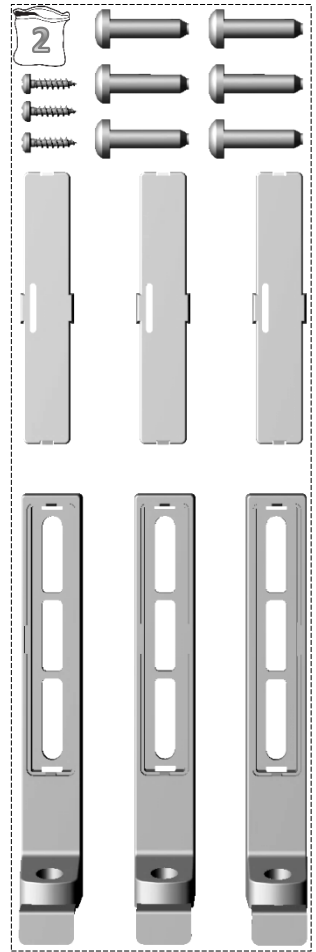

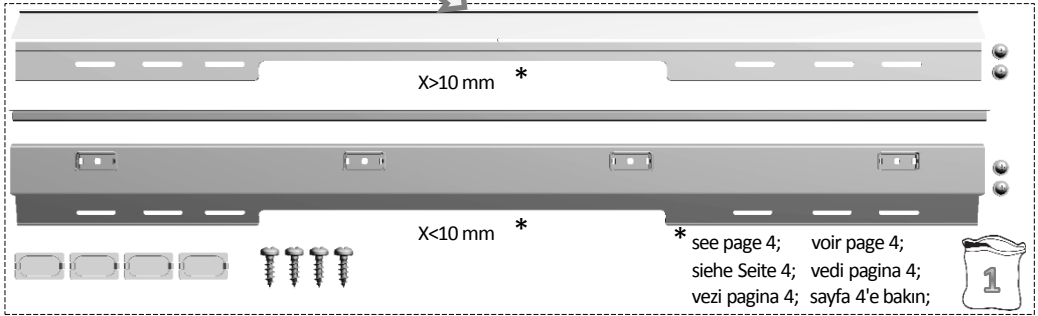
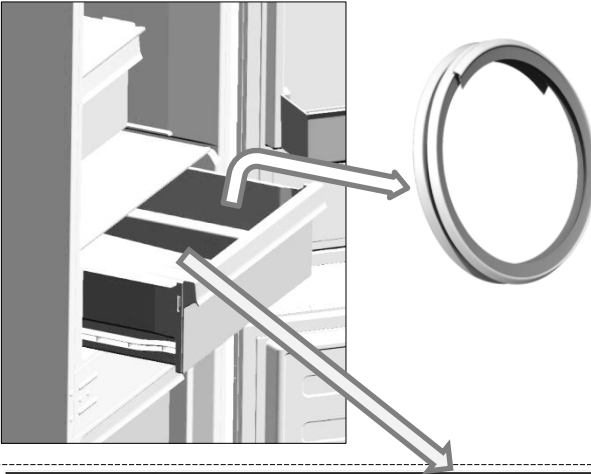
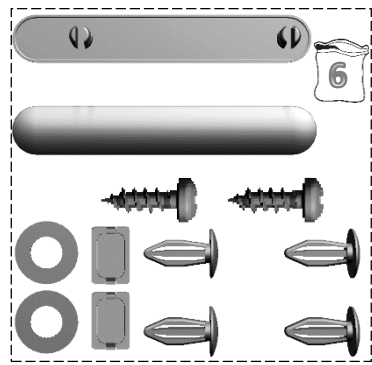
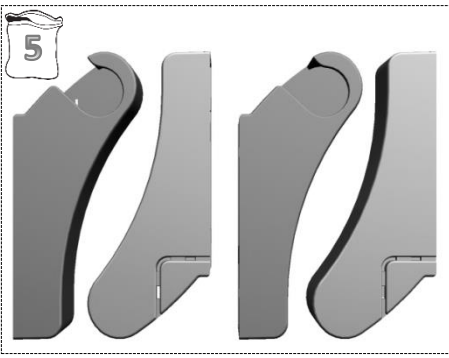

- If the subject parts are not included in the product you have purchased, then it is valid for other models.
- Si les pièces concernées ne sont pas incluses dans le produit que vous avez acheté, elles sont valables pour d'autres modèles.
- Falls Teile nicht zum Lieferumfang des erworbenen Produktes zählen, gelten sie für andere Modelle.
- Se le parti in oggetto non sono incluse nell'apparecchio acquistato, significa che sono da intendersi per altri modelli.
- În cazul în care unele componente nu sunt incluse în produsul pe care l-ați achiziționat, atunci sunt valabile pentru alte modele.
- Satın almış olduğunuz üründe ilgili parçalar yoksa başka modeller için geçerlidir.

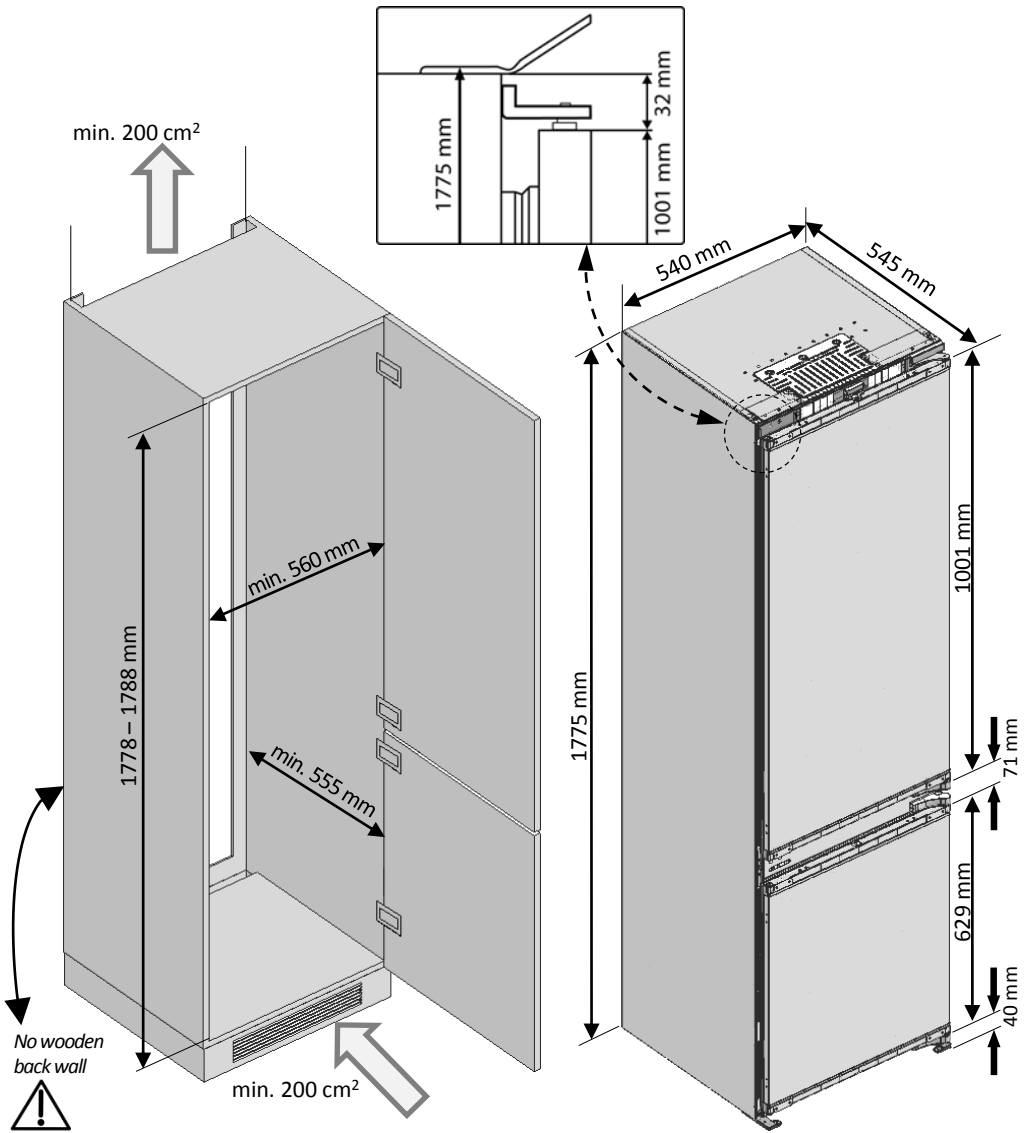

The back wall of the wooden cabinet must be left open completely to kitchen wall in order to allow sufficient air circulation to cool down the condenser unit for energy efficiency.

La paroi arrière du meuble en bois doit être laissée complètement ouverte contre le mur de la cuisine, afin de permettre une circulation d'air suffisante pour refroidir le produit.

Die Rückseite des Holzschrank muss zur Küchenwand hin vollständig offen bleiben, damit eine ausreichende Luftzirkulation für die Abkühlung des Kondensators zur Gewährleistung der Energieeffizienz sorgt.

La parete posteriore dell'armadio in legno deve essere lasciata completamente aperta verso la parete della cucina per consentire una circolazione d'aria sufficiente a raffreddare il condensatore per garantire una sufficiente alimentazione.

Pentru a avea eficiență energetică, partea posterioară a dulapului către peretele bucătăriei trebuie să fie lăsată complet deschisă, pentru a permite o circulație de aer suficientă care să răcească condensatorul.

Enerji tasarrufu için buzdolabı arkasında yeterli hava sirkülasyonu sağlanmalıdır. Bu amaçla buzdolabının içine yerleştirileceği ahşap kabinin arka yüzeyi kapatılmamalıdır.

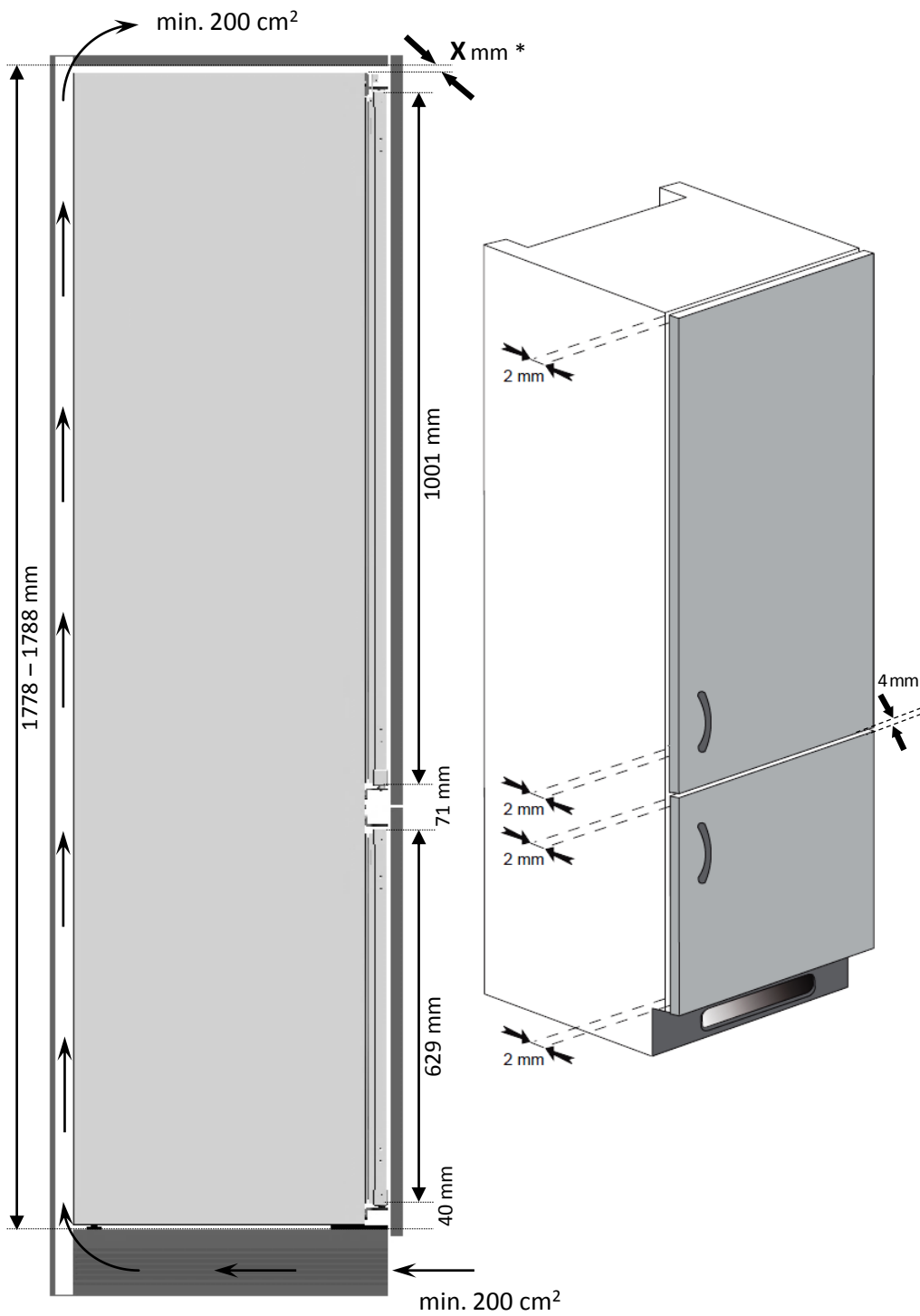

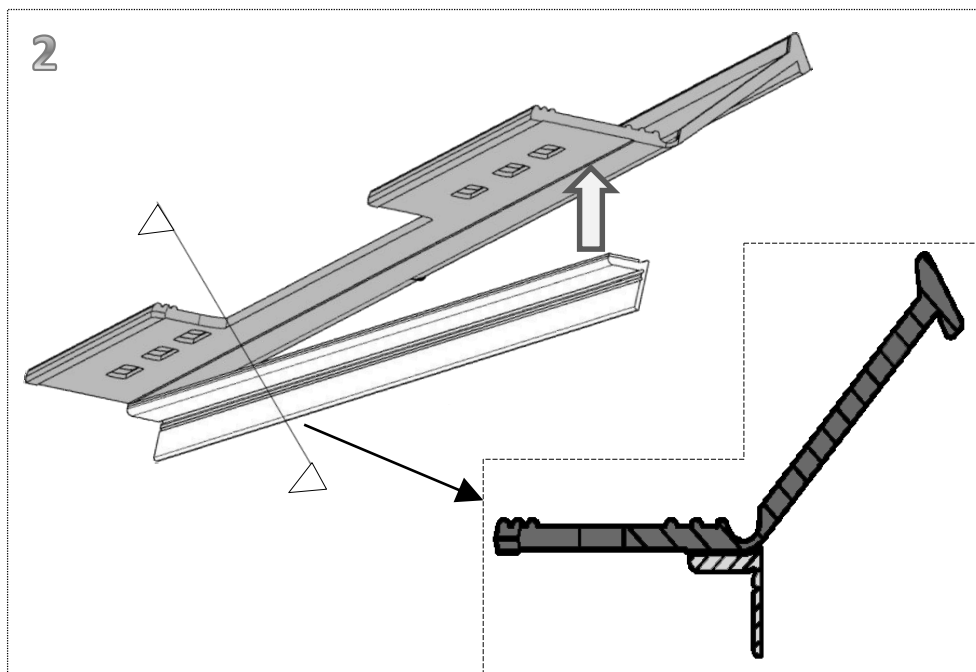
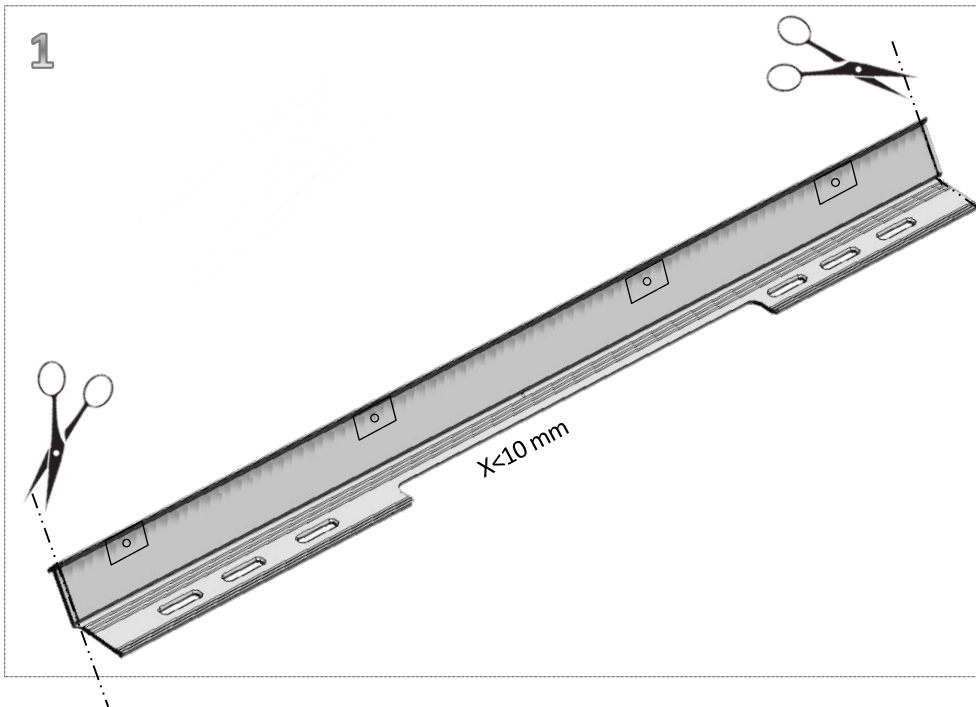

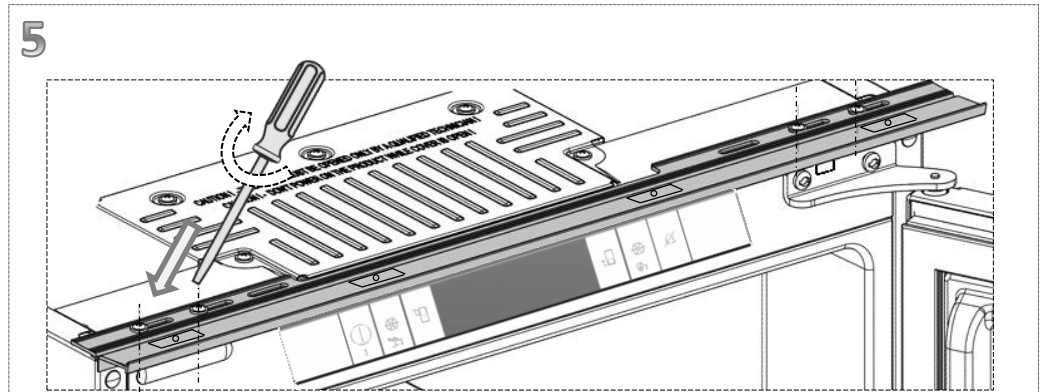
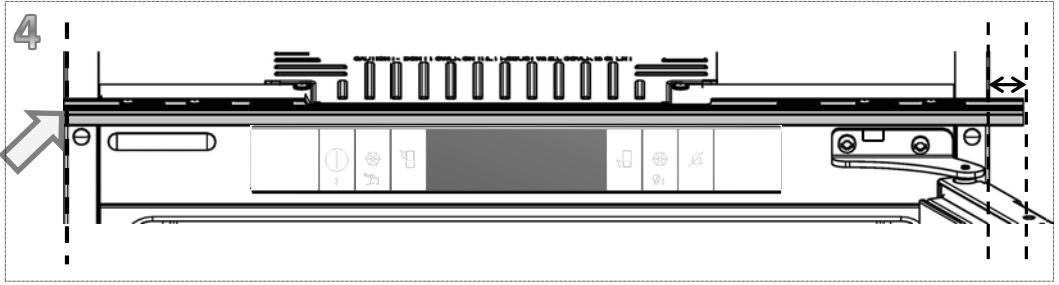
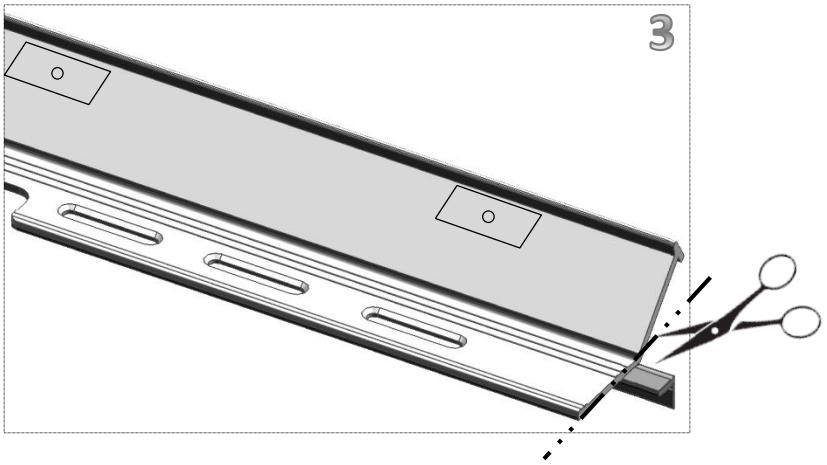

Note: screws for connecting top plastic part should not be screwed very hard, because of moving the plastic part easily left or right side.

Remarque: les vis pour fixer l'accessoire en plastique sur la partie supérieure ne doivent pas être vissées à fond, afin d'éviter tout déplacement latéral de cette pièce pendant le vissage.

Hinweis: Die Schrauben zum Fixieren des Kunststoffteils sollten nicht zu fest angezogen werden, da sich das Kunststoffteil ansonsten nach links oder rechts verschieben kann.

Nota: viti per connettere la parte in plastica superiore non devono essere serrate, per consentire il movimento della parte in plastica a sinistra o a destra.

Notă: șuruburile pentru conectarea părții superioare din plastic nu trebuie să fie înșurubate foarte tare, pentru ca aceasta să poată fi mișcată ușor de la stânga la dreapta.

Not: numara ile gösterilen montaj adimında üst bağlantı plastiğini kaydırabilmek için bağlantının yapıldığı vidaları tam sıkmayınız.

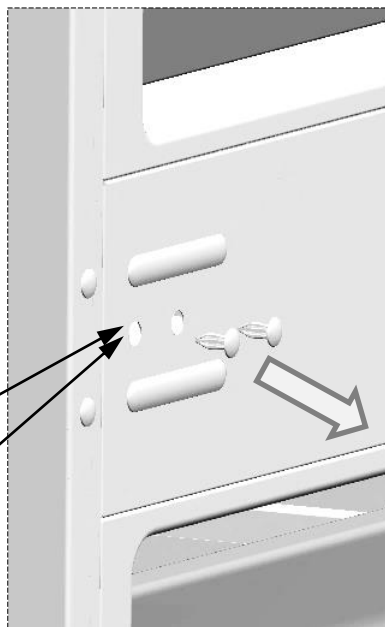
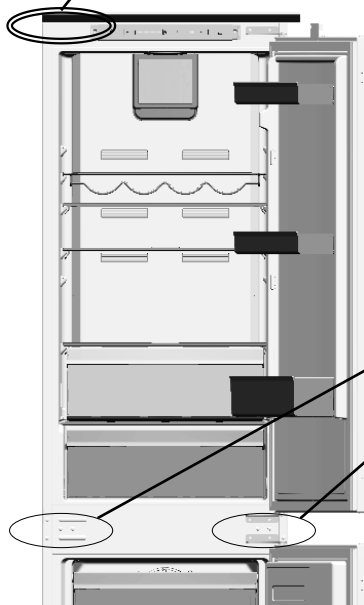
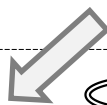
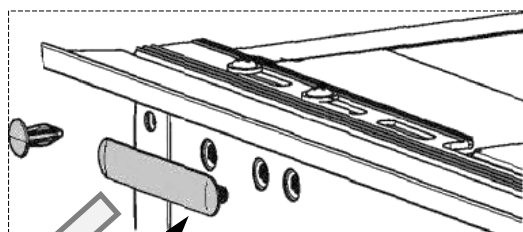

6

7

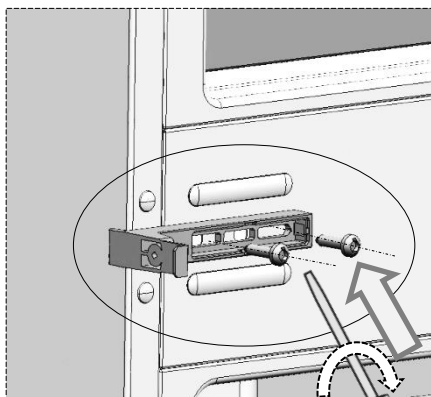
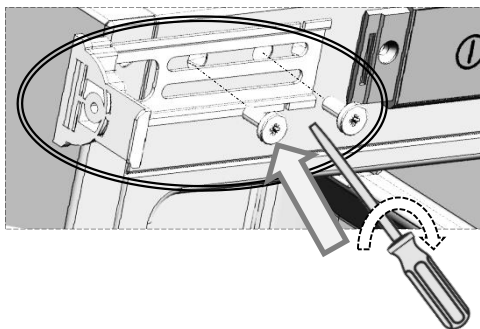

Installation step for 7: screws should not be fully tightened at this stage.

A l'étape 7 de l'installation: les vis ne doivent pas être vissées à fond.

Installationschritt 7: die schrauben sollten nicht zu fest angezogen werden.

Fase di installazione per 7: le viti non devono essere completamente serrate in questa fase.

Instalare pasul 7: șuruburile nu trebuie să fie înșurubate foarte tare.

7 için kurulum adımı: vidalar bu aşamada tamamen sıkılmamalıdır.

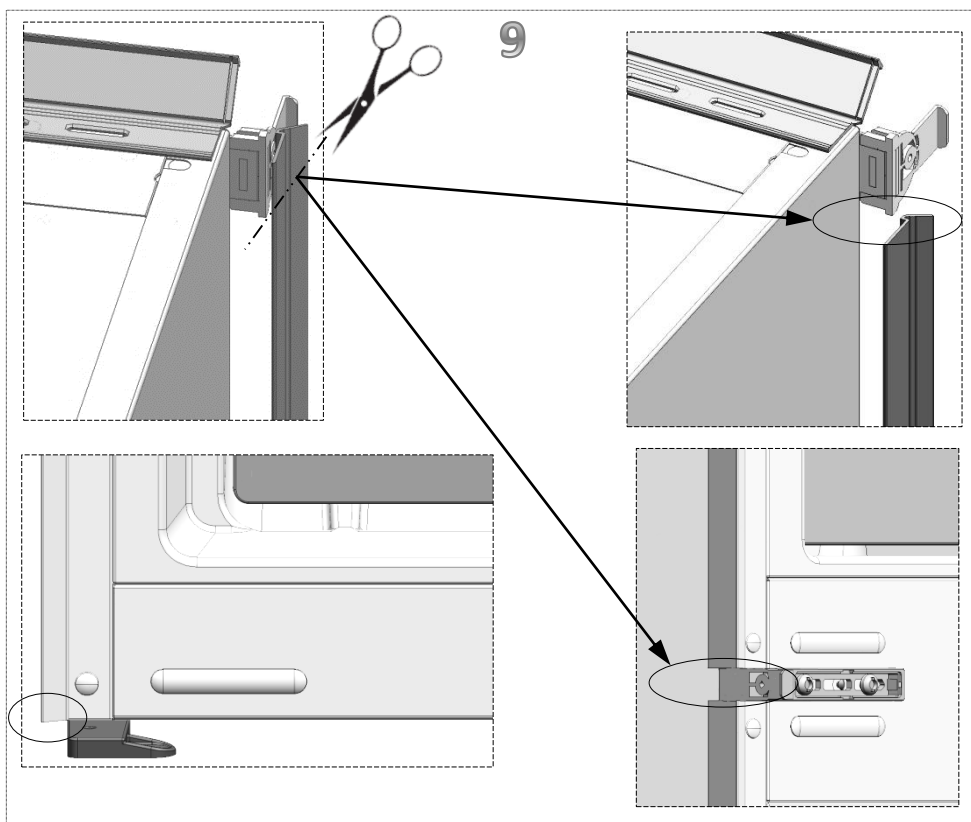
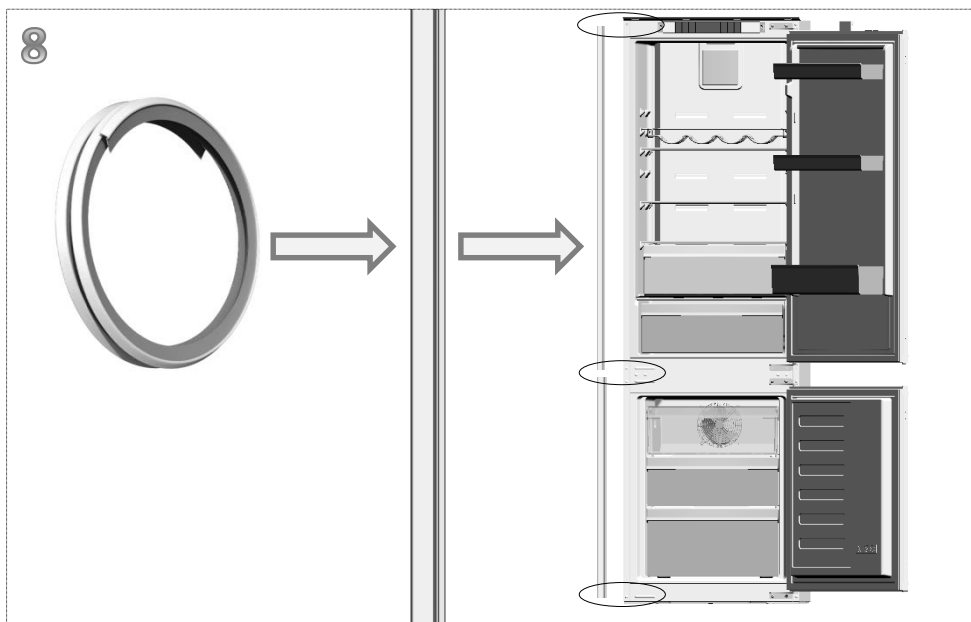

10

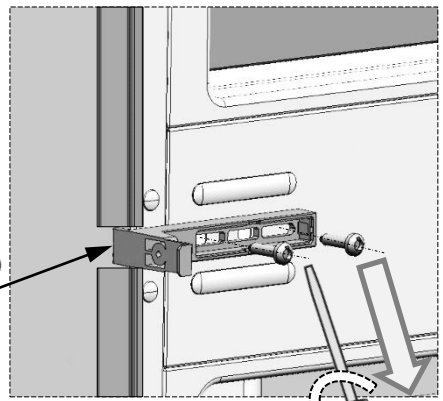
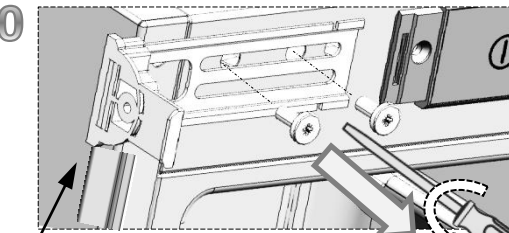

Installation step for 10: screws must be unscrewed.
A l'étape 10 de l'installation: les vis doivent être dévissées.
Installationsschritt 10: Schrauben müssen abgeschraubt werden.
Fase di installazione per 10: le viti devono essere svitate.
Instalare pasul 10: șuruburile trebuie deșurubate.
10 için kurulum adımı: vidalar sökülmeli olmalı.

11

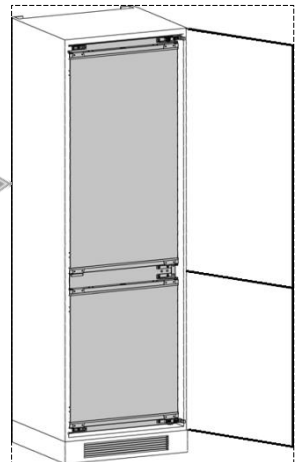
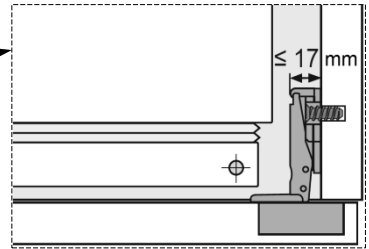
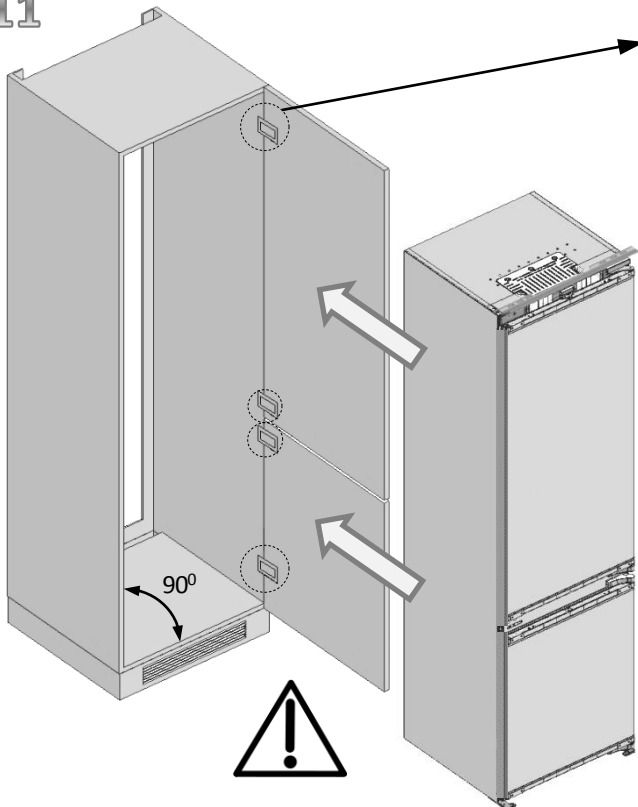

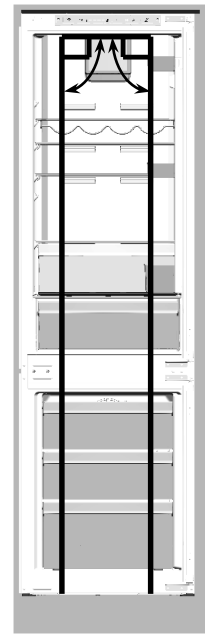
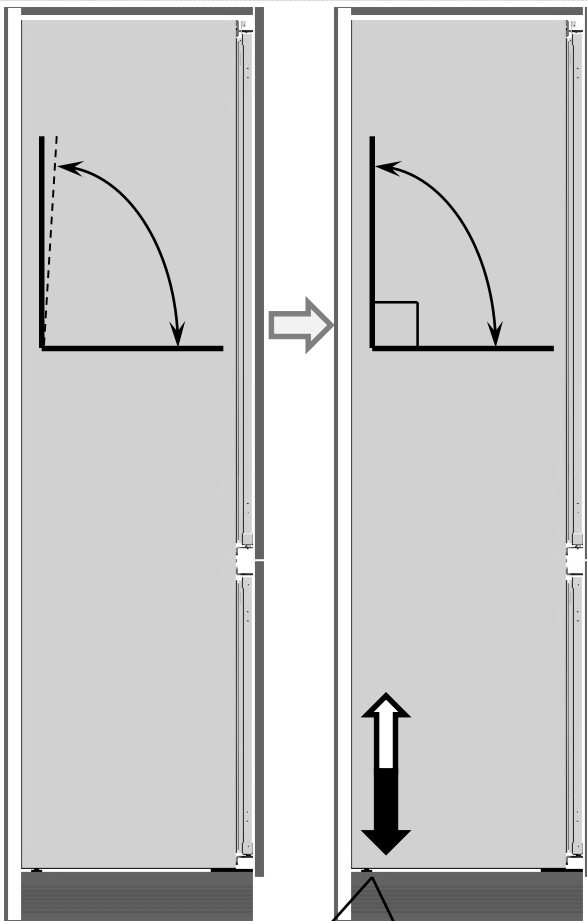

Adjusting the legs

If your refrigerator is unbalanced: You can balance your refrigerator by turning the legs of it as illustrated in the figure. The corner where the leg exists is lowered when you turn in the direction of black arrow and raised when you turn in the opposite direction. Taking help from someone to slightly lift the refrigerator will facilitate this process.

Réglage des pieds

Si votre réfrigérateur est déséquilibré: Vous pouvez l'équilibrer en tournant les pieds de celui-ci comme illustré sur le dessin ci-dessus. Pour abaisser le produit, veuillez tourner les pieds dans le sens inverse des aiguilles d'une montre (flèches noires). Pour monter le produit, veuillez tourner dans le sens contraire (flèches blanches). Lever légèrement l'avant du produit, avec l'aide d'une personne tierce, vous facilitera le processus.

Füße einstellen

Wenn Ihr Kühlschrank nicht absolut gerade steht: Sie können den Kühlschrank – wie in der Abbildung gezeigt – durch Drehen der FüÙe ausbalancieren. Wenn Sie in Richtung des schwarzen Pfeils drehen, senkt sich die Ecke, an der sich der Fuß befindet. Beim Drehen in Gegenrichtung wird die Ecke angehoben. Diese Arbeit fällt erheblich leichter, wenn ein Helfer das Gerät etwas anhebt.

Regolazione dei piedini

Se il frigorifero non è in equilibrio: È possibile bilanciare il frigorifero ruotando i piedini come illustrato in figura. L'angolo in cui i piedini sono più bassi quando girati in direzione della freccia nera e rialzati quando girati in direzione opposta. Un aiuto per sollevare leggermente il frigorifero faciliterà tale processo.

Ajustarea picioarelor

Dacă frigiderul este neechilibrat: Puteți echilibra frigiderul prin rotirea picioarelor sale așa cum este reprezentat în schiță. Colțul unde există piciorul se coboară atunci când roțiți în direcția săgeții negre și se ridică atunci când roțiți în direcția opusă. Acest procedeu va fi mai ușor dacă cineva vă ajută să ridicați ușor frigiderul.

Ayakların Ayarlanması

Buzdolabınız dengesiz duruyorsa: Buzdolabınızın ayaklarını şekildedeki gibi döndürerek dengeli durmasını sağlayabilirsiniz. Siyah ok yönüne döndürüldüğünde ayağın bulunduğu köşe alçalır, diğer yöne döndürüldüğünde ise yükselir. Bu işlem yapılırken birinden dolabı hafifçe kaldırması için yardım almanız kolaylık sağlayacaktır.

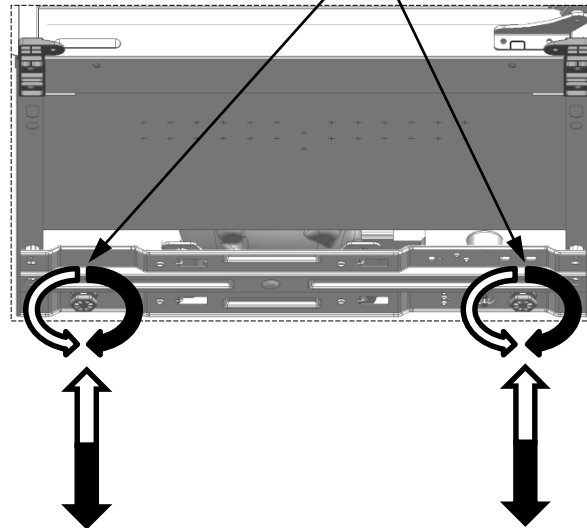

13

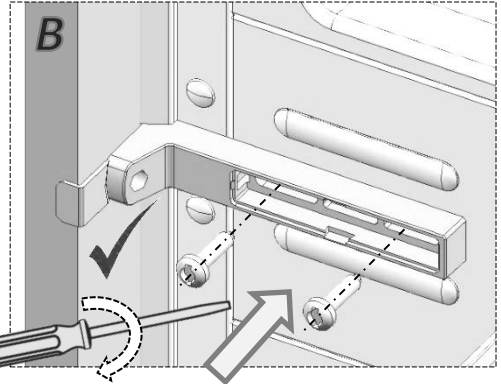
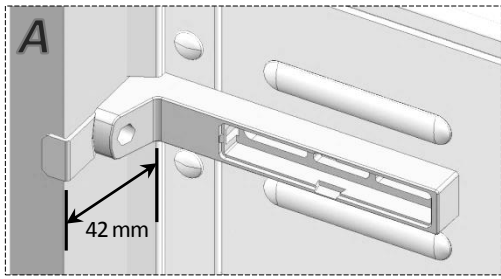
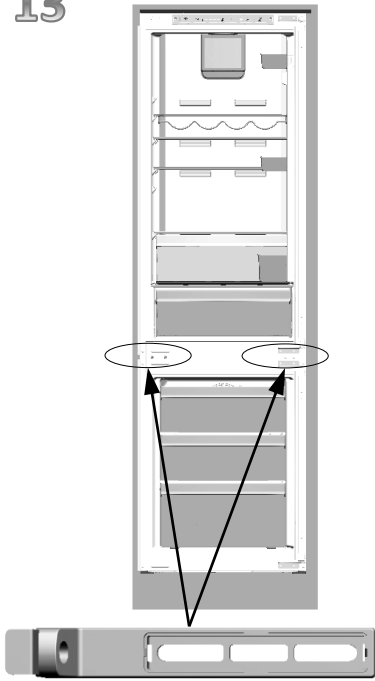

Installation step for 13_B: screws should not be fully tightened at this stage.

A l'étape 13_B de l'installation: les vis ne doivent pas être vissées à fond.

Installationsschritt 13_B: die schrauben sollten nicht zu fest angezogen werden.

Fase di installazione per 13_B: le viti non devono essere completamente serrate in questa fase.

Instalare pasul 13_B: șuruburile nu trebuie să fie înșurubate foarte tare.

13_B için kurulum adımı: vidalar bu aşamada tamamen sıkılmamalıdır.

14

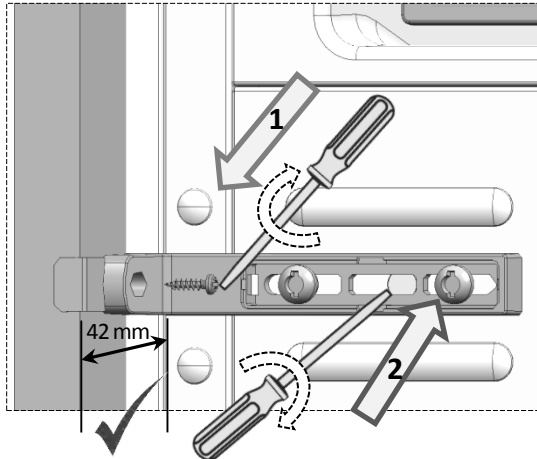
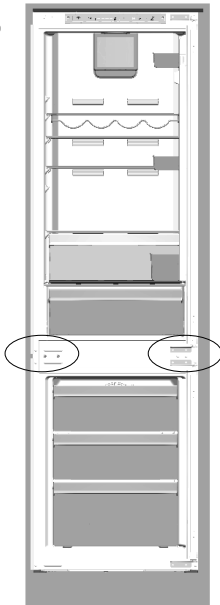

Installation step for 14: screws should be fully tightened at this stage.

A l'étape 14 de l'installation: les vis doivent être vissées à fond.

Installationsschritt 14: schrauben sollen vollständig angezogen sein.

Fase di installazione per 14: le viti devono essere completamente serrate in questa fase.

Instalare pasul 14: în această etapă, șuruburile trebuie să fie înșurubate complet.

14 için kurulum adımı: bu aşamada vidalar tamamen sıkılmalıdır.

15

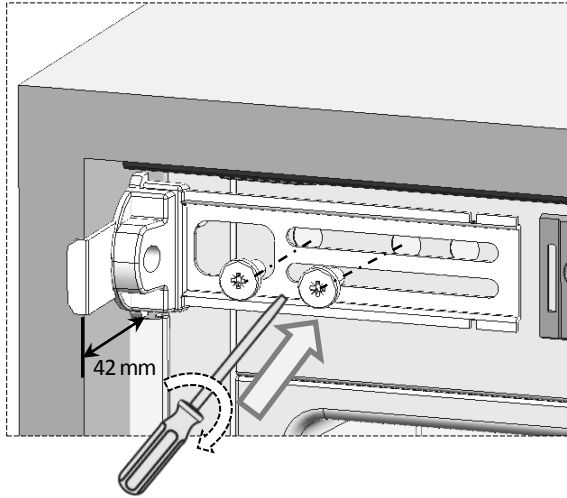
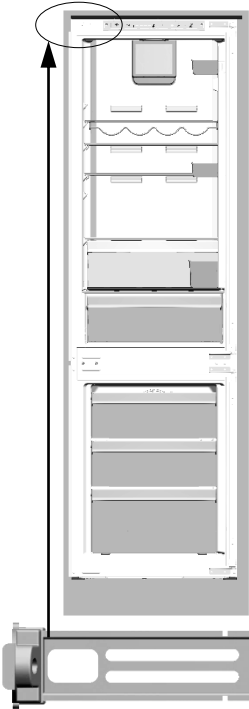

Installation step for 15: screws should not be fully tightened at this stage.

A l'étape 15 de l'installation: les vis ne doivent pas être vissées à fond.

Installationsschritt 15: die schrauben sollten nicht zu fest angezogen werden.

Fase di installazione per 15: le viti non devono essere completamente serrate in questa fase.

Instalare pasul 15: șuruburile nu trebuie să fie înșurubate foarte tare.

15 için kurulum adımı: vidalar bu aşamada tamamen sıkılmamalıdır.

16

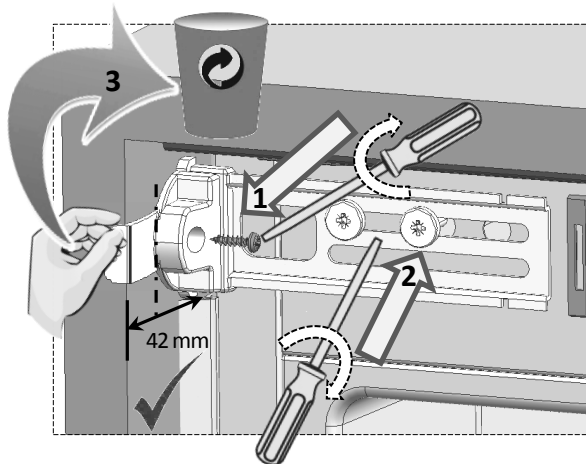

Installation step for 16: screws should be fully tightened at this stage.

A l'étape 16 de l'installation: les vis doivent être vissées à fond.

Installationsschritt 16: schrauben sollen vollständig angezogen sein.

Fase di installazione per 16: le viti devono essere completamente serrate in questa fase.

Instalare pasul 16: în această etapă, șuruburile trebuie să fie înșurubate complet.

16 için kurulum adımı: bu aşamada vidalar tamamen sıkılmalıdır.

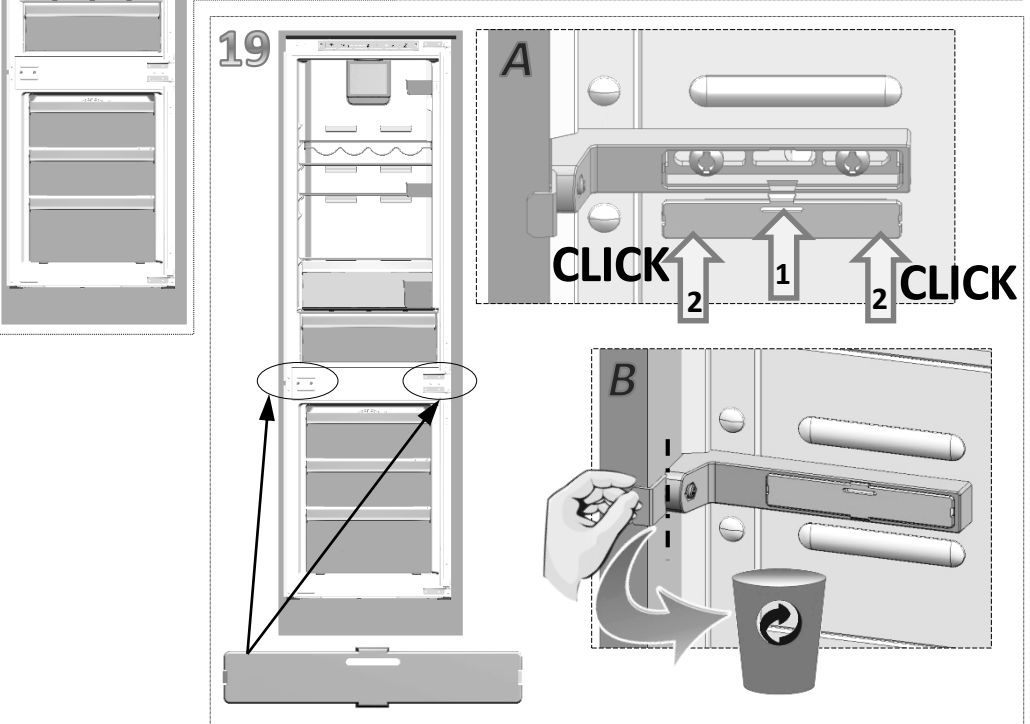
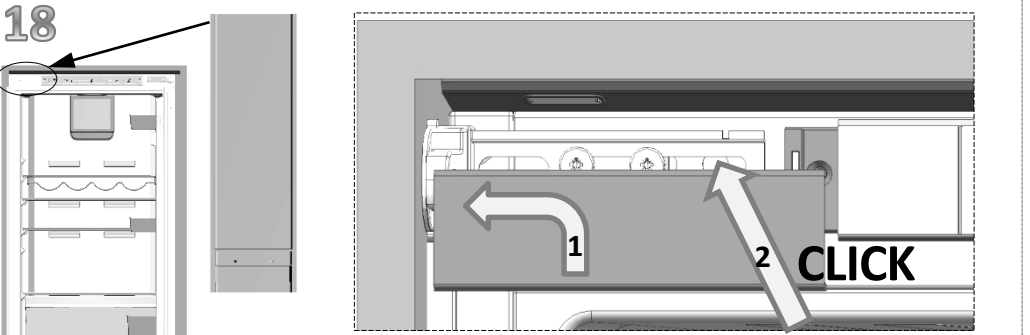
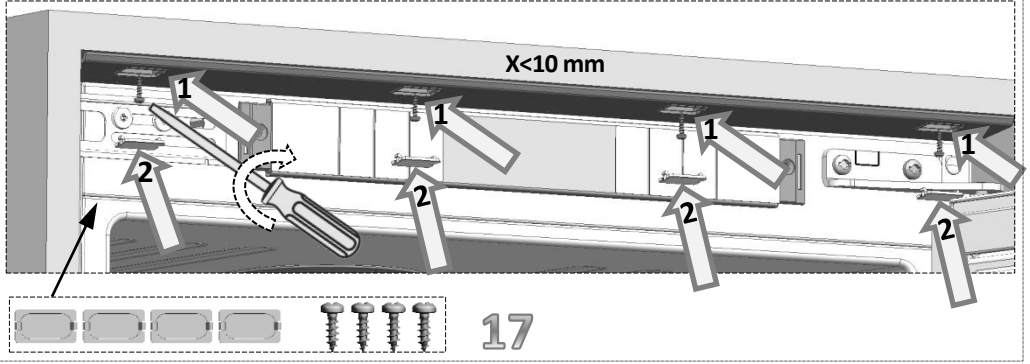

20

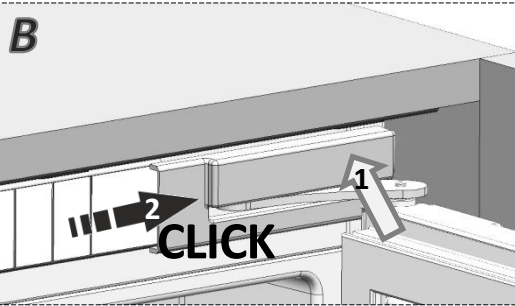
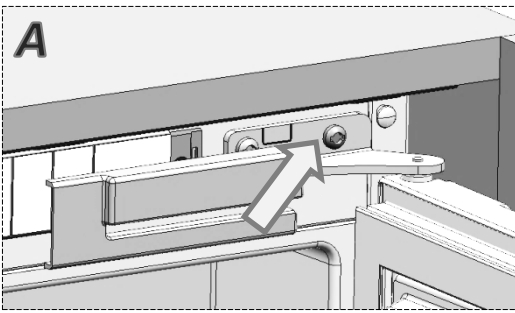

21

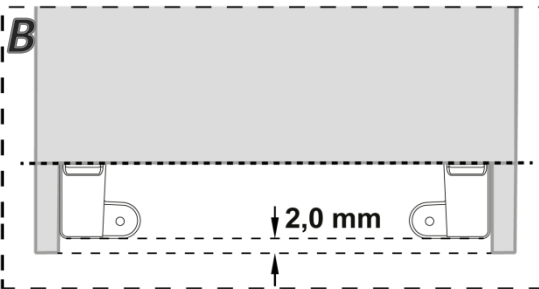
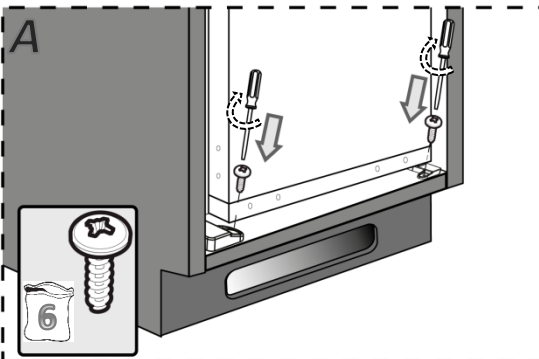
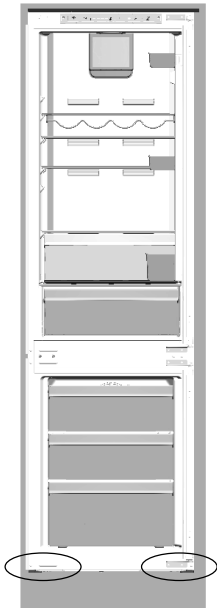

21*

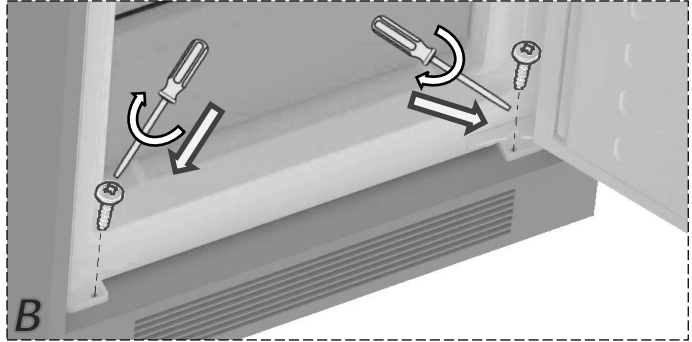
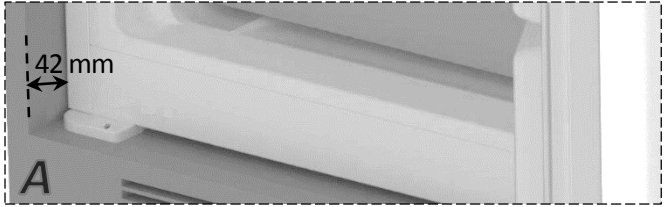
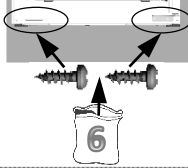
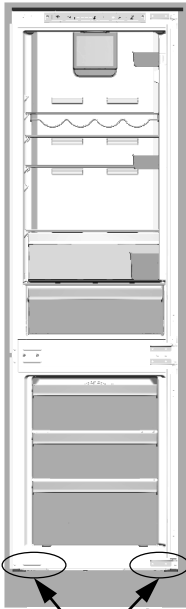

Note: Installation step for 21* - only for some models.

Remarque: A l'étape 21* de l'installation - uniquement pour certains modèles.

Hinweis: Installationsschritt 21* - nur für einige Modelle.

Nota: Fase di installazione per 21* - solo per alcuni modelli.

Notă: Instalare pasul 21* - doar pentru anumite modele.

Not: 21* için montaj adımı - sadece bazı modeller için.



21*

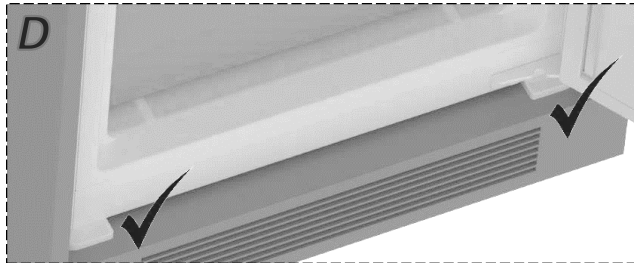
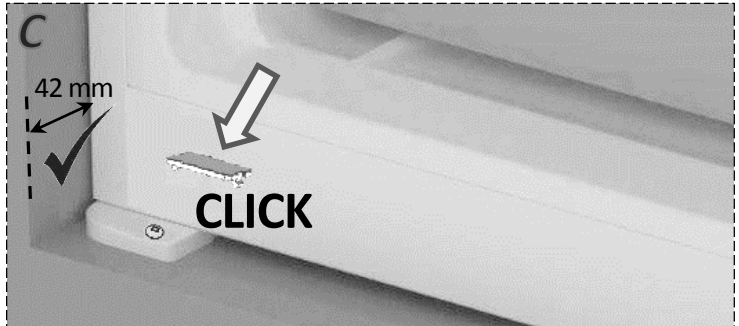

Note: Installation step for 21* - only for some models.

Remarque: A l'étape 21* de l'installation - uniquement pour certains modèles.

Hinweis: Installationsschritt 21* - nur für einige Modelle.

Nota: Fase di installazione per 21* - solo per alcuni modelli.

Notă: Instalare pasul 21* - doar pentru anumite modele.

Not: 21* için montaj adımı - sadece bazı modeller için.



22

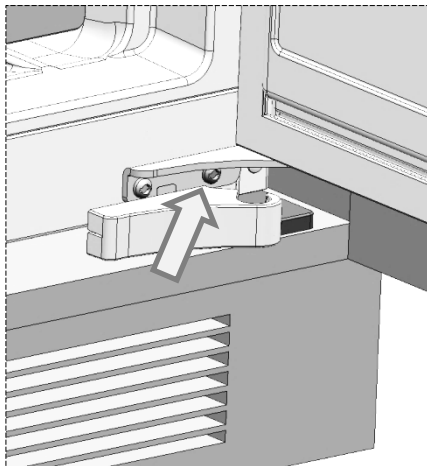

23

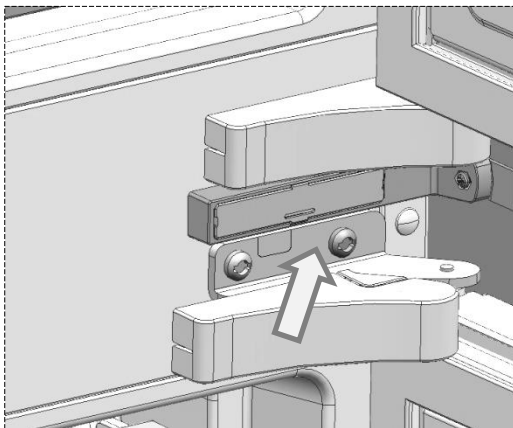

24

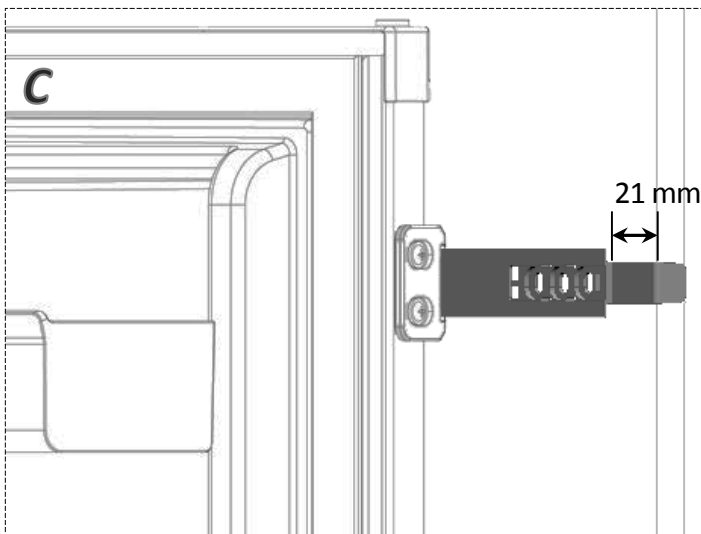
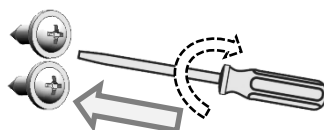
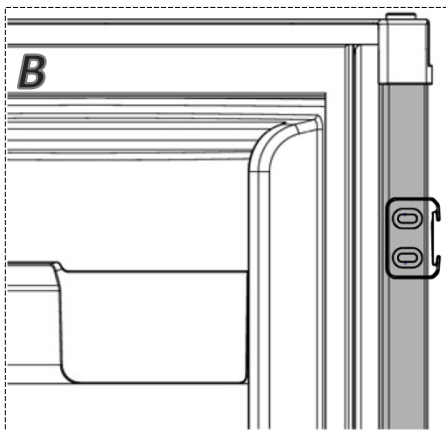
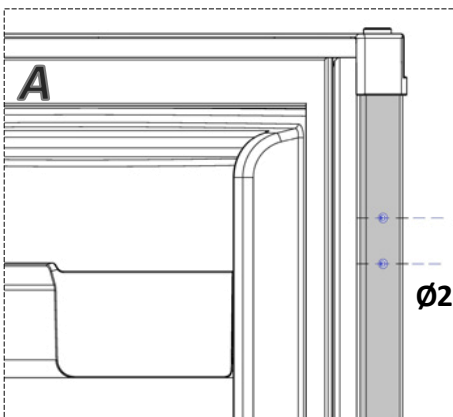

25

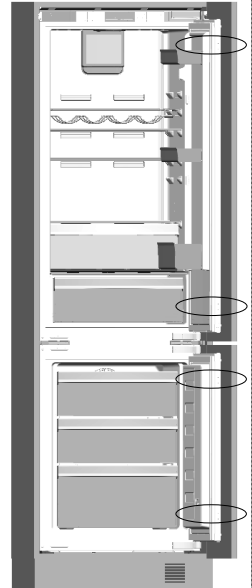
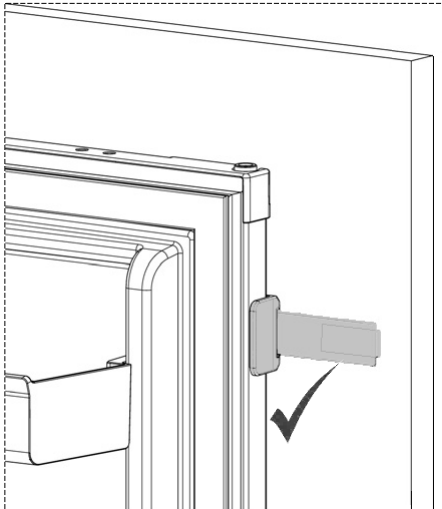
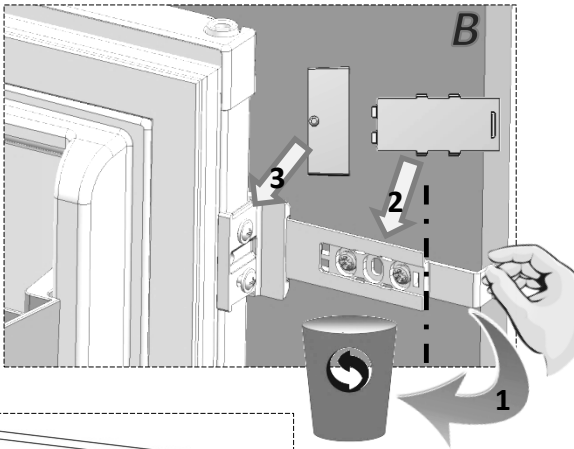
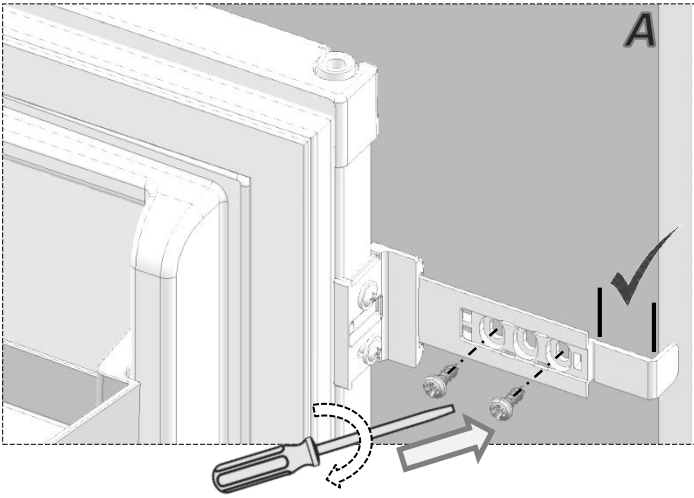



Note: Installation step for 6*, 7*, 13* and 19* - only for Italy models.

Remarque: A l'étape 6*, 7*, 13* et 19* de l'installation - uniquement pour les modèles italiens.

Hinweis: Installationsschritt 6*, 7*, 13* und 19* - nur für Italien Modelle.

Nota: Fase di installazione per 6*, 7*, 13* e 19* - solo per i modelli italiani.

Notă: Instalare pasul 6*, 7*, 13* și 19* - doar pentru modelele de Italia.

Not: 6*, 7*, 13* ve 19* için montaj adımı - yalnızca İtalya modelleri için.

